

PLAN VIEW - FOUNDATION LAYOUT  
SCALE = 1 : 120

COLUMN - B.O.M.

QTY	MARK #	DESCRIPTION	MAT'L	O.A.L.	WT - EA.	WT - GALV
1	A-2	COLUMN ASSY	W8X31 (ASSY)	15'-0"	562.21	581.73
1	A-3	COLUMN ASSY	W8X31 (ASSY)	15'-0"	567.86	587.74
1	B-11	COLUMN ASSY	W8X31 (ASSY)	15'-0"	513.88	531.87
1	B-31	COLUMN ASSY	W8X31 (ASSY)	15'-0"	513.88	531.87
1	C-1	COLUMN ASSY	W8X31 (ASSY)	15'-0"	556.70	576.19
1	C-2	COLUMN ASSY	W8X31 (ASSY)	15'-0"	567.39	587.25
1	C-3	COLUMN ASSY	W8X31 (ASSY)	15'-0"	567.39	587.25
1	C-4	COLUMN ASSY	W8X31 (ASSY)	15'-0"	556.70	576.19
1	D-1	COLUMN ASSY	W8X31 (ASSY)	15'-0"	554.13	573.53
1	D-2	COLUMN ASSY	W8X31 (ASSY)	15'-0"	567.39	587.25
1	D-3	COLUMN ASSY	W8X31 (ASSY)	15'-0"	567.39	587.25
1	D-4	COLUMN ASSY	W8X31 (ASSY)	15'-0"	556.70	576.19
1	E-11	COLUMN ASSY	W8X31 (ASSY)	15'-0"	513.88	531.87
1	E-31	COLUMN ASSY	W8X31 (ASSY)	15'-0"	513.88	531.87
1	F-2	COLUMN ASSY	W8X31 (ASSY)	15'-0"	562.42	582.11
1	F-3	COLUMN ASSY	W8X31 (ASSY)	15'-0"	562.42	582.11

TOTAL WEIGHT (GALV) = 9,113 LBS.

PROPRIETARY AND CONFIDENTIAL  
 THE INFORMATION CONTAINED IN THIS DRAWING IS THE SOLE PROPERTY OF SWAGER COMMUNICATIONS, INC. ANY REPRODUCTION IN PART OR AS A WHOLE WITHOUT THE WRITTEN PERMISSION OF SWAGER COMMUNICATIONS, INC. IS PROHIBITED.

CUSTOMER: **SWAGER COMMUNICATIONS INC.**  
 SITE: **FOUNDATION LAYOUT**  
 DRAWN: **HBORG** 01/18/19  
 CHECKED: **J.NEFF** 01/18/19  
 DWG. NO. 3906-19-A02  
 SCALE 1:120  
 WEIGHT:  
 SHEET 1 OF 1

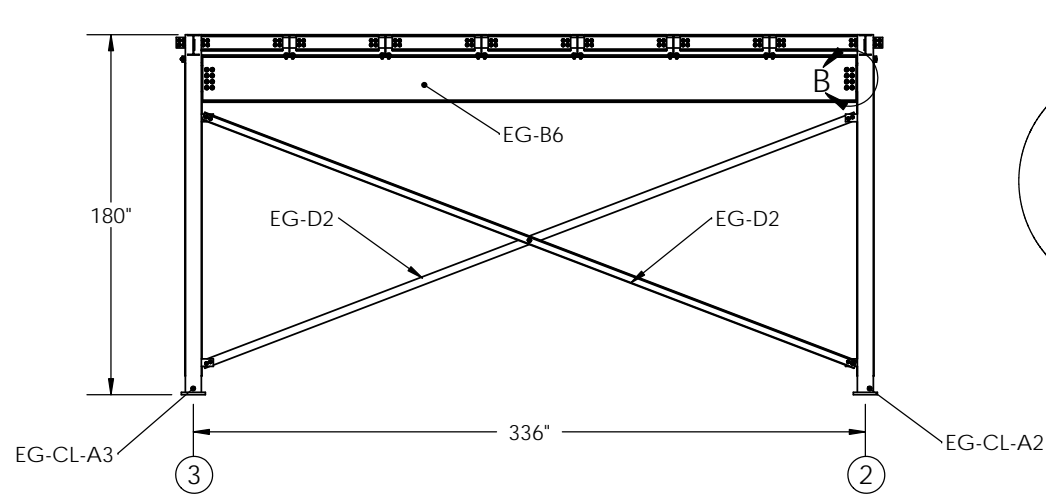

**COLUMN BRACING @ LINE A**  
SCALE = 1:96

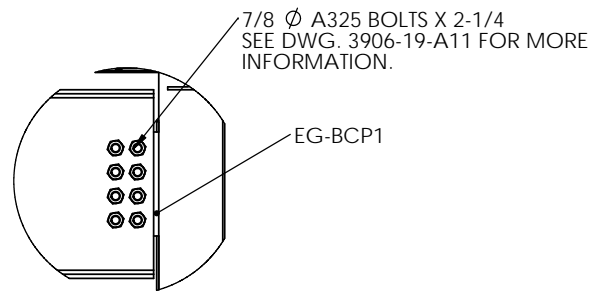

**DETAIL B**  
SCALE 1 : 24

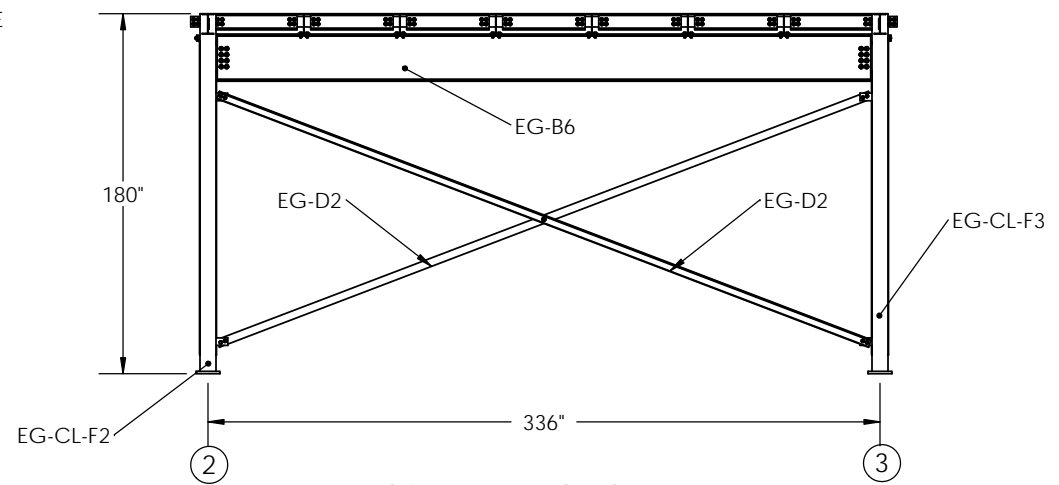

**COLUMN BRACING @ LINE F**  
SCALE = 1:96

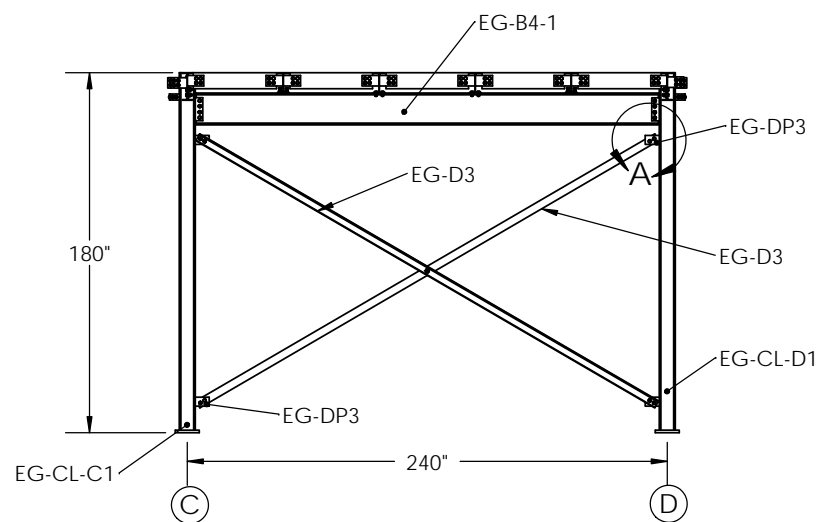

**COLUMN BRACING @ LINE 1**  
SCALE = 1:96

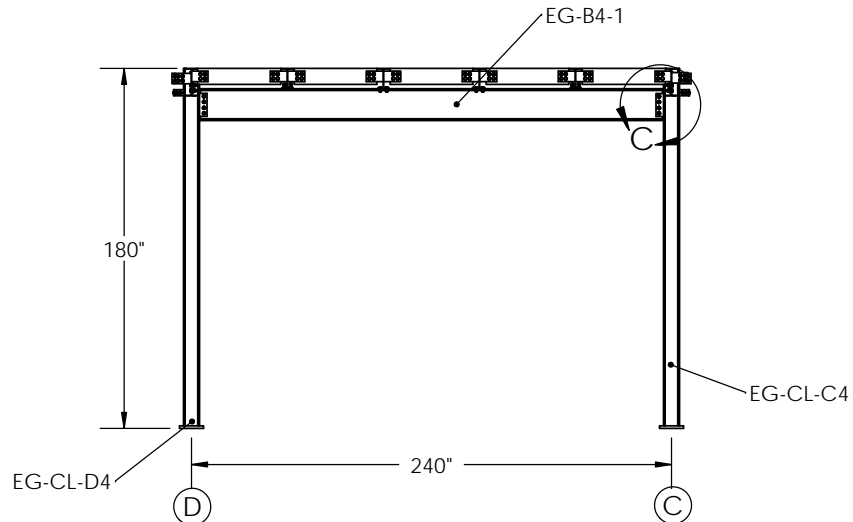

**COLUMN BRACING @ LINE 4**  
SCALE = 1:96

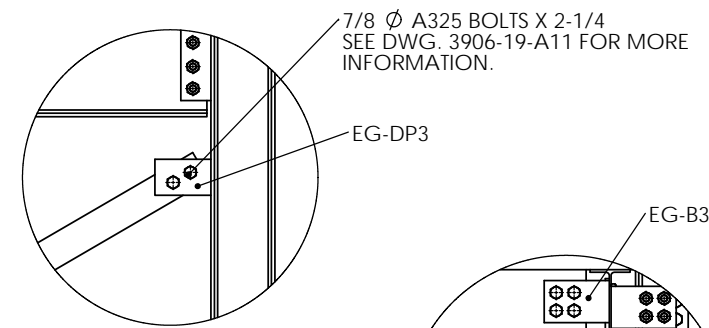

**DETAIL A**  
SCALE 1 : 24

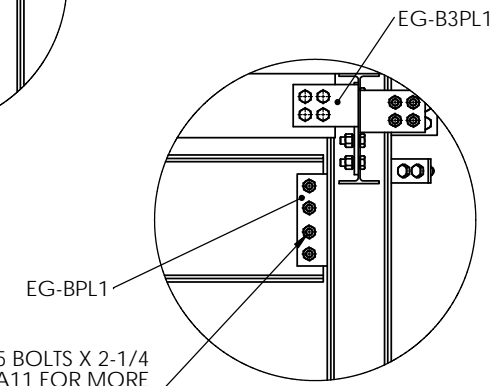

**DETAIL C**  
SCALE 1 : 24

**NOTE:**  
SEE DWG. 3906-19-A11: CONNECTION PLATE DETAILS - CONNECTION 1-9

<b>BRACING B.O.M.</b>							
QTY	PART #	DESCRIPTION	MATERIAL	LENGTH	WT-EA.	WT-GALV	WT-TTL
4	EG-D2	DIAGONAL BRACING	L 4 X 4 X 1/4	29'-0 7/8"	197.18	204.07	816.30
2	EG-B6	MAIN GIRT	W24 X 55	27'-2 11/16"	1497.44	1549.86	3099.70
2	EG-D3	DIAGONAL BRACING	L 4 X 4 X 1/4	22'-1 1/2"	145.91	151.02	302.04
2	EG-B4-1	MAIN GIRT	W16 X 31	19'-3"	596.19	617.06	1234.12

PROPRIETARY AND CONFIDENTIAL  
 THE INFORMATION CONTAINED IN THIS DRAWING IS THE SOLE PROPERTY OF SWAGER COMMUNICATIONS, INC. ANY REPRODUCTION IN PART OR AS A WHOLE WITHOUT THE WRITTEN PERMISSION OF SWAGER COMMUNICATIONS, INC. IS PROHIBITED.

CUSTOMER: **SWAGER COMMUNICATIONS INC.**

TITLE: COLUMN BRACING PLAN  
 DWG. NO. 3906-19-A03  
 SCALE 1:96 WEIGHT: SHEET 1 OF 1

SITE: HBERG  
 DRAWN: J.NEFF  
 CHECKED: 01/18/19

REV

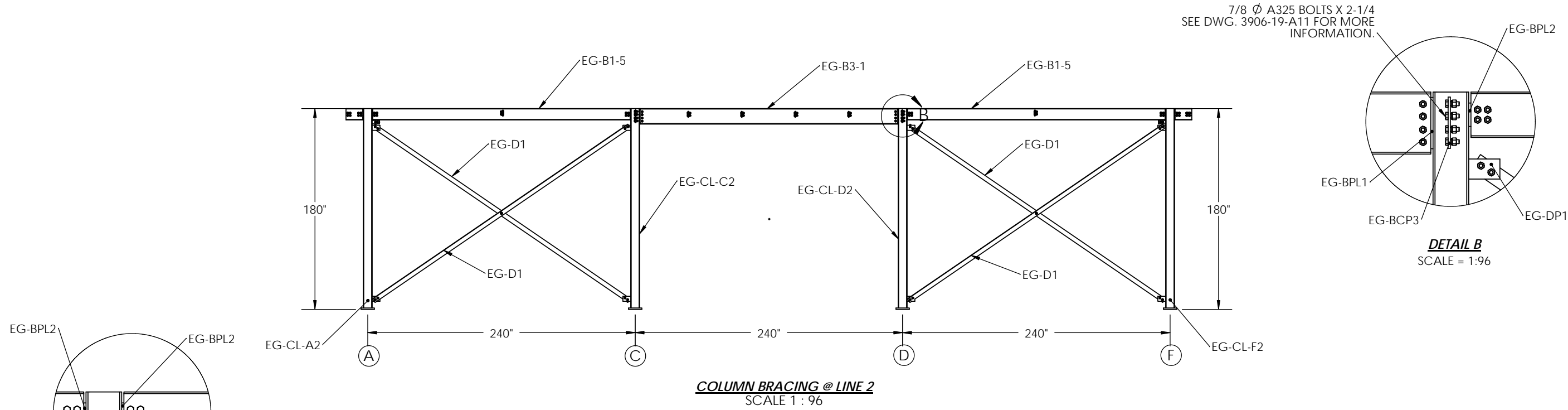

**COLUMN BRACING @ LINE 2**  
SCALE 1 : 96

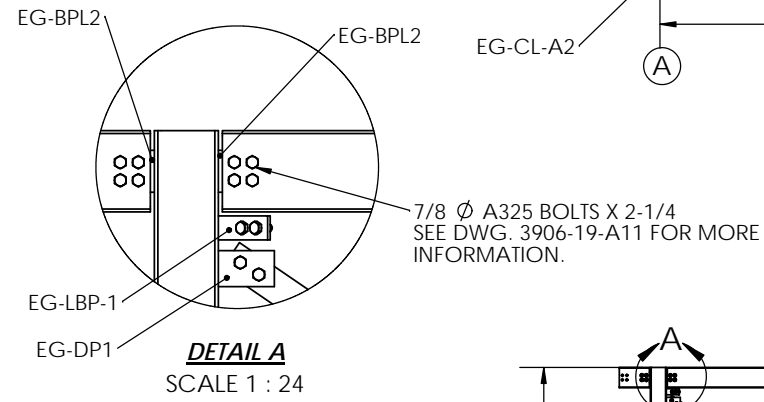

**DETAIL A**  
SCALE 1 : 24

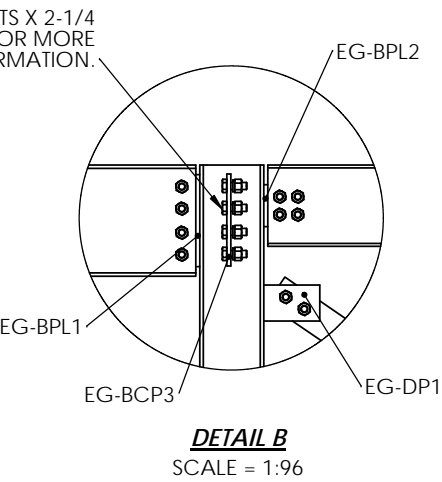

**DETAIL B**  
SCALE = 1:96

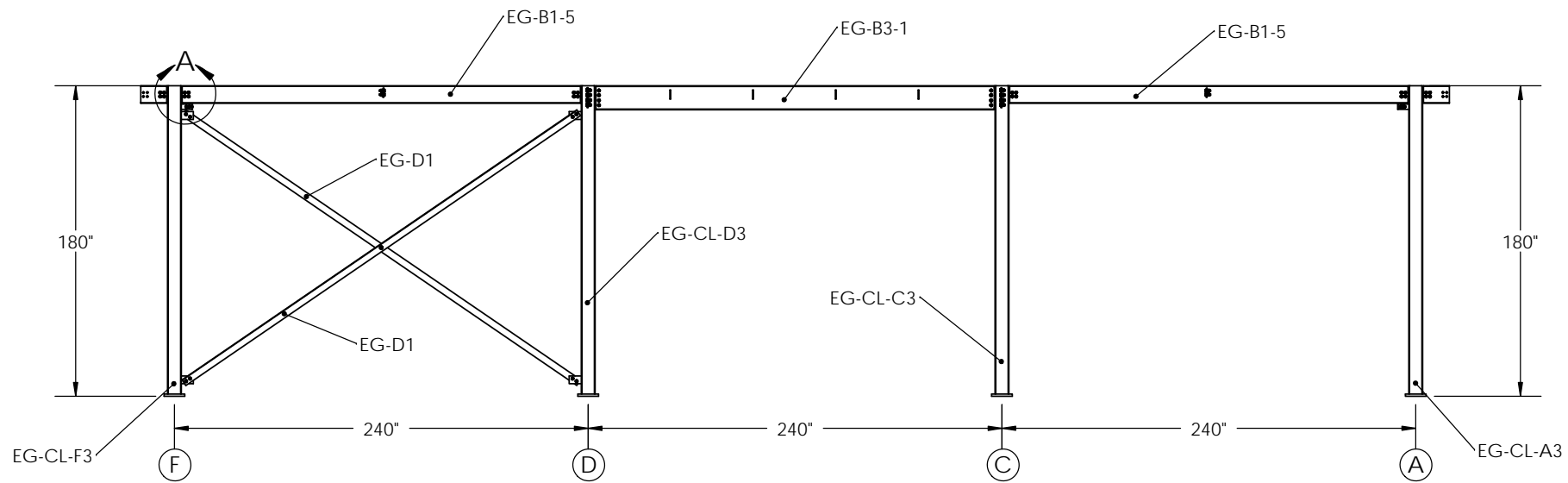

**COLUMN BRACING @ LINE 3**  
SCALE 1 : 96

**NOTE:**  
SEE DWG. 3906-19-A11; CONNECTION PLATE DETAILS - CONNECTION 1-9

<b>BRACING B.O.M.</b>							
<u>QTY</u>	<u>PART #</u>	<u>DESCRIPTION</u>	<u>MATERIAL</u>	<u>LENGTH</u>	<u>WT-EA.</u>	<u>WT-GALV</u>	<u>WT-TTL</u>
6	EG-D1	DIAGONAL BRACING	L 4 X 4 X 1/4	23'-1 5/16"	152.40	157.74	946.5
4	EG-B1-5	MAIN GIRT	W10 X 22 W-BEAM	19'-3"	437.96	453.29	1,813.16
2	EG-B3-1	MAIN GIRT	W14 X 26 W-BEAM	19'-3"	535.875	554.64	1,109.26

PROPRIETARY AND CONFIDENTIAL  
 THE INFORMATION CONTAINED IN THIS DRAWING IS THE SOLE PROPERTY OF SWAGER COMMUNICATIONS, INC. ANY REPRODUCTION IN PART OR AS A WHOLE WITHOUT THE WRITTEN PERMISSION OF SWAGER COMMUNICATIONS, INC. IS PROHIBITED.

CUSTOMER: **SWAGER COMMUNICATIONS INC.**

SITE: **HBORG** DRAWN: **J.NEFF** CHECKED: **J.NEFF**

TITLE: **COLUMN BRACING PLAN** DWG. NO. **3906-19-A04** SCALE 1: **1:96** WEIGHT: **1:96**

REV SHEET 1 OF 1

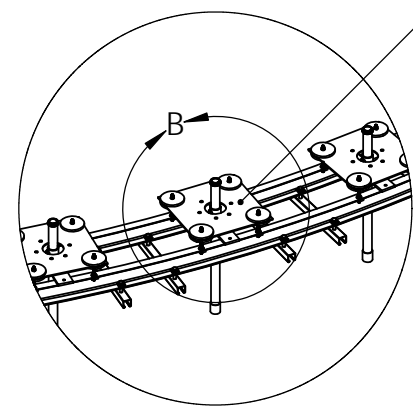

**DETAIL A**  
SCALE 1 : 36

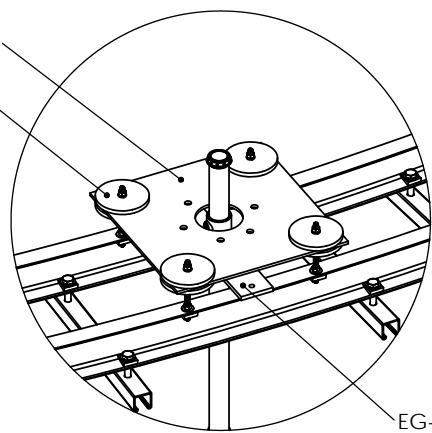

**DETAIL B**  
SCALE 1 : 16

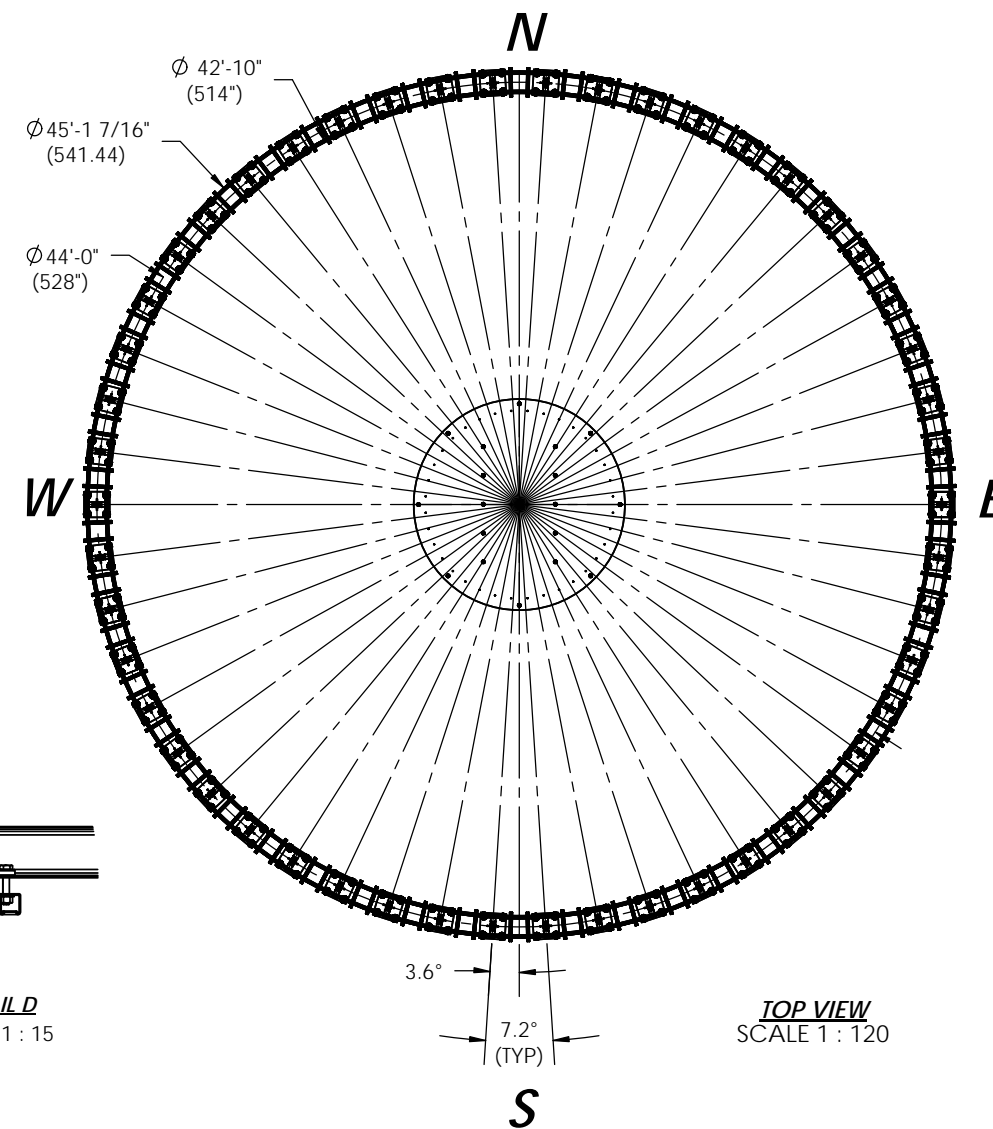

**TOP VIEW**  
SCALE 1 : 120

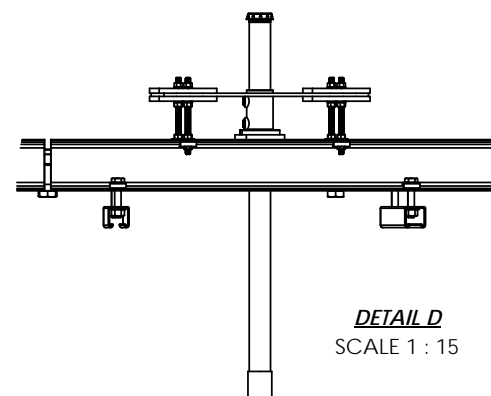

**DETAIL D**  
SCALE 1 : 15

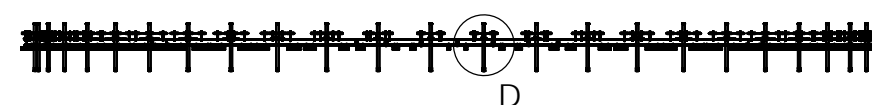

**DETAIL C**  
SCALE 1 : 8

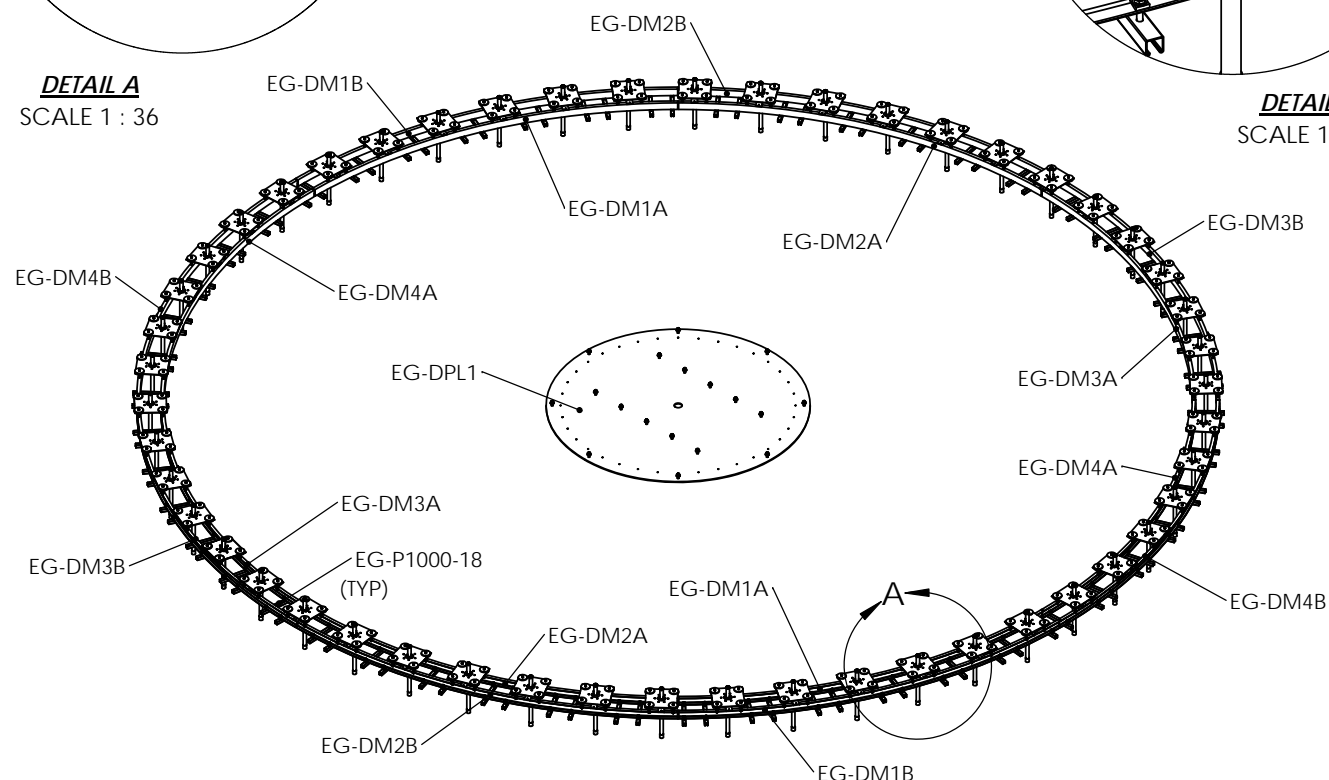

**DOPPLER MOUNT ASSEMBLY**  
SCALE 1 : 96

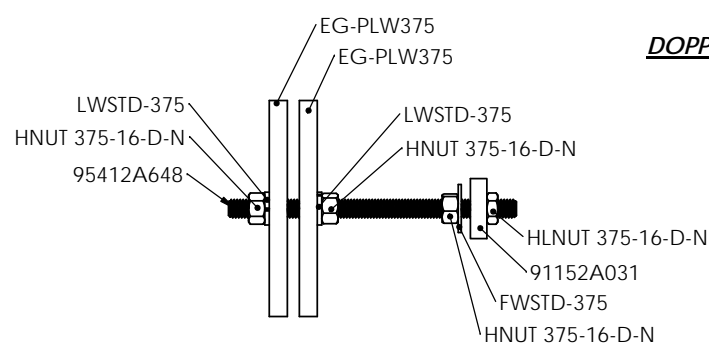

**PLATE WASHER ASSEMBLY**  
MK. PLW375 (ASSY)

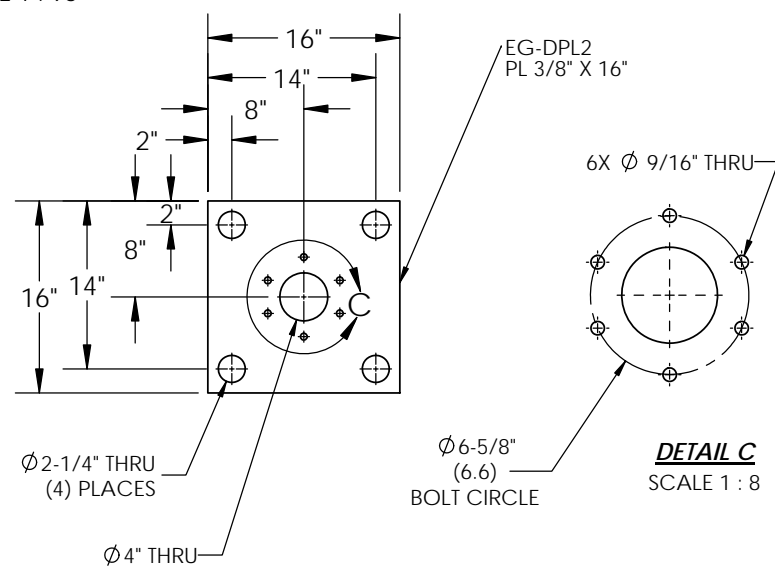

**DOPPLER MOUNT ASSEMBLY - B.O.M.**

QTY.	PART NUMBER	DESCRIPTION	MATERIAL	LENGTH	WT-EA	WT-GALV	WT-TTL
2	EG-DM1A	ROLLED C-CHANNEL MOUNT	C4X7.25 C-CHANNEL	16'-4 1/4"	121.54	125.8	251.6
2	EG-DM2A	ROLLED C-CHANNEL MOUNT	C4X7.25 C-CHANNEL	16'-4 1/4"	121.54	125.8	251.6
2	EG-DM3A	ROLLED C-CHANNEL MOUNT	C4X7.25 C-CHANNEL	16'-4 1/4"	121.54	125.8	251.6
2	EG-DM4A	ROLLED C-CHANNEL MOUNT	C4X7.25 C-CHANNEL	16'-4 1/4"	121.54	125.8	251.6
2	EG-DM1B	ROLLED C-CHANNEL MOUNT	C4X7.25 C-CHANNEL	17'-1 7/16"	127.23	131.69	263.4
2	EG-DM2B	ROLLED C-CHANNEL MOUNT	C4X7.25 C-CHANNEL	17'-1 7/16"	127.23	131.69	263.4
2	EG-DM3B	ROLLED C-CHANNEL MOUNT	C4X7.25 C-CHANNEL	17'-1 7/16"	127.23	131.69	263.4
2	EG-DM4B	ROLLED C-CHANNEL MOUNT	C4X7.25 C-CHANNEL	17'-1 7/16"	127.23	131.69	263.4
1	EG-DPL1	DOPPLER MOUNT PLATE	PL 1/2" X 11'-0" Ø	11'-0" Ø	1,940.58	2,008.5	2,008.5
50	EG-DPL2	DOPPLER MOUNT PLATE	PL 3/8" X 1'-4"	1'-4"	27.2	28.2	1,407.6
50	EG-DPL3	DOPPLER MOUNT PLATE	PL 1/4" X 3"	1'-2"	4.46	4.63	231.3
200	PLW375 (ASSY)	LOWER PLATE MOUNT ASS'Y	PL 3/8" X 4-1/2"	4-1/2" Ø	3.64	3.77	753.5
100	EG-P1000	UNISTRUT BRACKET	P1000 UNISTRUT	1'-6"	2.83	2.93	293.0

**PLW375 - PLATE WASHER - B.O.M.**

QTY.	PART NUMBER	DESCRIPTION
1	95412A648	3/8" THREADED ROD
1	91152A031	3/8" WEDGE WASHER
2	EG-PLW375	3/8" PLATE WASHER
2	LWSTD-375	3/8" STANDARD LOCK WASHER
3	HNUST 375-16-D-N	3/8" STANDARD HEX NUT
1	HLNUT 375-16-D-N	3/8" STANDARD LOCK NUT
1	FWSTD-375	3/8" STANDARD FLAT WASHER

**CUSTOMER:** SWAGER COMMUNICATIONS INC.

**SITE:** HBERG

**DATE:** 01/18/19

**DRAWN BY:** J.NEFF

**CHECKED BY:** J.NEFF

**TITLE:** DOPPLER MOUNT ASSEMBLY

**DWG. NO.:** 3906-19-A10

**SCALE:** 1:1

**WEIGHT:** 1 OF 1

**REV:**

**PROPRIETARY AND CONFIDENTIAL**

THE INFORMATION CONTAINED IN THIS DRAWING IS THE SOLE PROPERTY OF SWAGER COMMUNICATIONS, INC. ANY REPRODUCTION IN PART OR AS A WHOLE WITHOUT THE WRITTEN PERMISSION OF SWAGER COMMUNICATIONS, INC. IS PROHIBITED.